

Pintle with 24 mm plate and vertical adjustment



Description

Cold-pressed steel pintle welded to a shaped steel plate whose width varies according to the GR size. Stainless steel screw for height adjustment.

Application

For narrow reveals or frames that are flush with the exterior wall.
The GR size depends on the F thickness of the rebate.

- Used in combination with fixed hinges to be chosen based on the shutter design.

Mounting

Use three 4.5x35 mm screws with thread suitable for the shutter material.

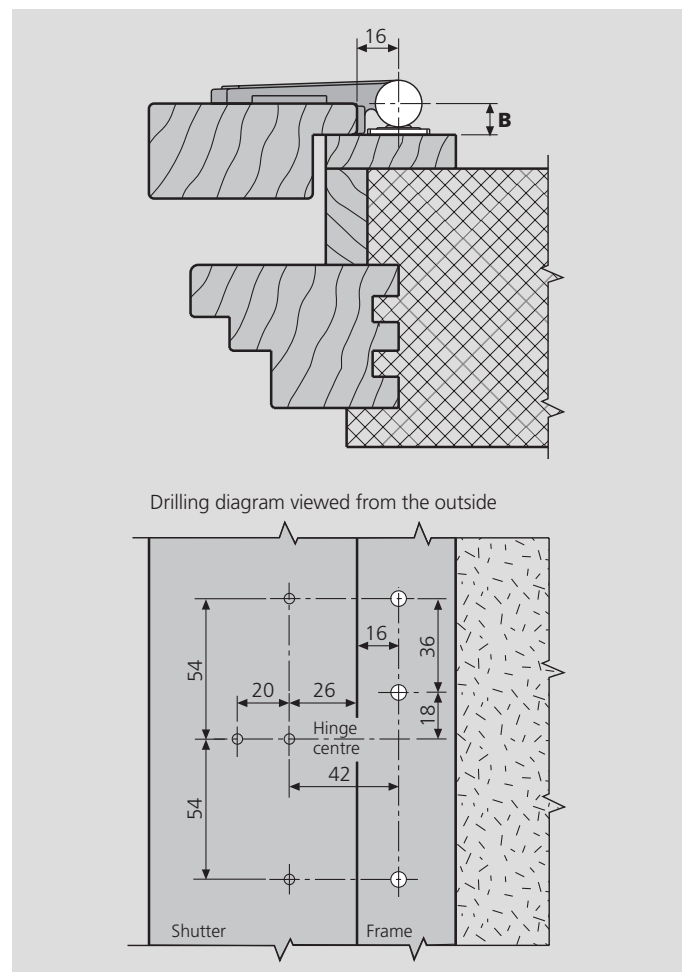
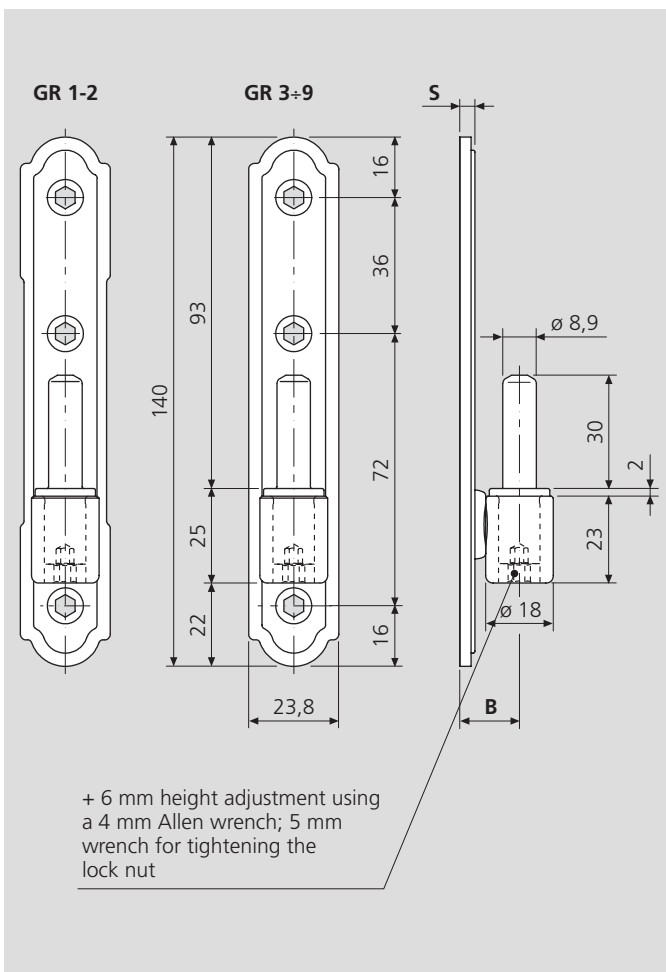

Order specifications

GR	B	S	Black finish	Bichromated finish
			Code	Code
1	12	2,7	H02924.12.93	H02924.12.04
2	15	4	H02924.15.93	H02924.15.04
3	18	4	H02924.18.93	H02924.18.04
4	20	4	H02924.20.93	H02924.20.04
5	22	4	H02924.22.93	H02924.22.04
6	24	4	H02924.24.93	H02924.24.04
7	26	4	H02924.26.93	H02924.26.04
8	28	4	H02924.28.93	H02924.28.04
9	30	4	H02924.30.93	H02924.30.04