

Fixed pintle with 18 mm plate



Description

Cold-pressed steel pintle welded to an 18 mm wide shaped steel plate, with pivot axis ranging from 22 to 30 mm based on the GR size.

Application

For shutters hinged to the soffit or to narrow frames that are flush with the exterior wall or have a slightly recessed reveal, or for monobloc systems with folding shutters. Used in combination with fixed hinges or hinges with horizontal adjustment, to be chosen based on the shutter design. When selecting the GR size, keep in mind that the F thickness of the rebate or of the shutter overlap, added to the H dimension of the hinge neck, must be equal to the B dis-

tance between centres of the pintle. See also the "Application Range" chapter.

Mounting

Use three 4.5x35 mm screws with suitable thread.

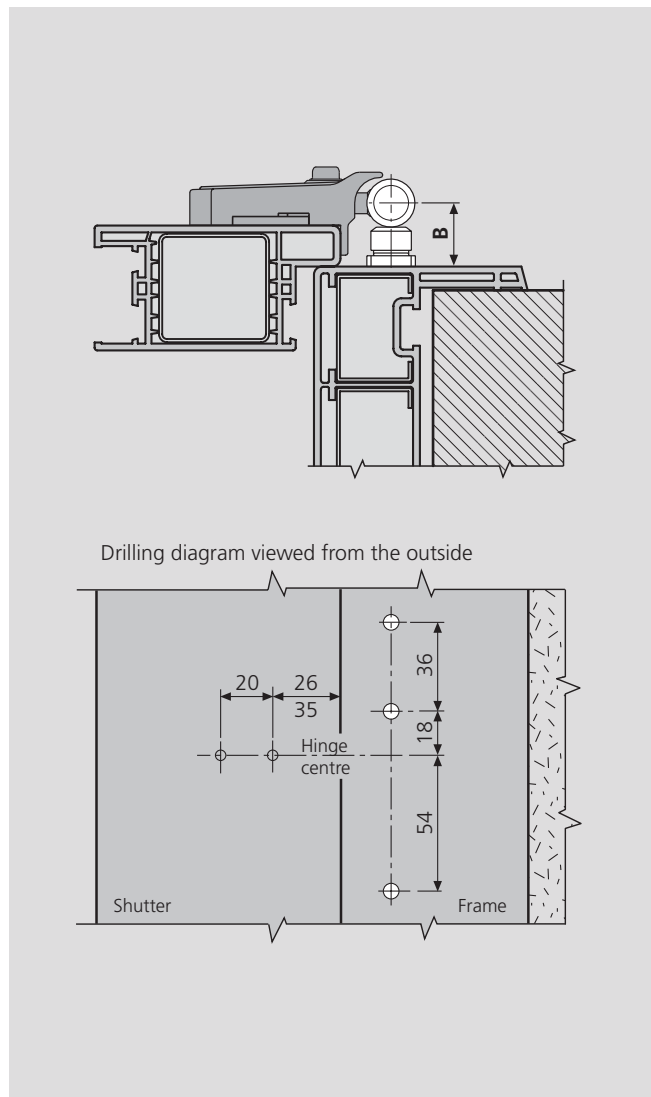
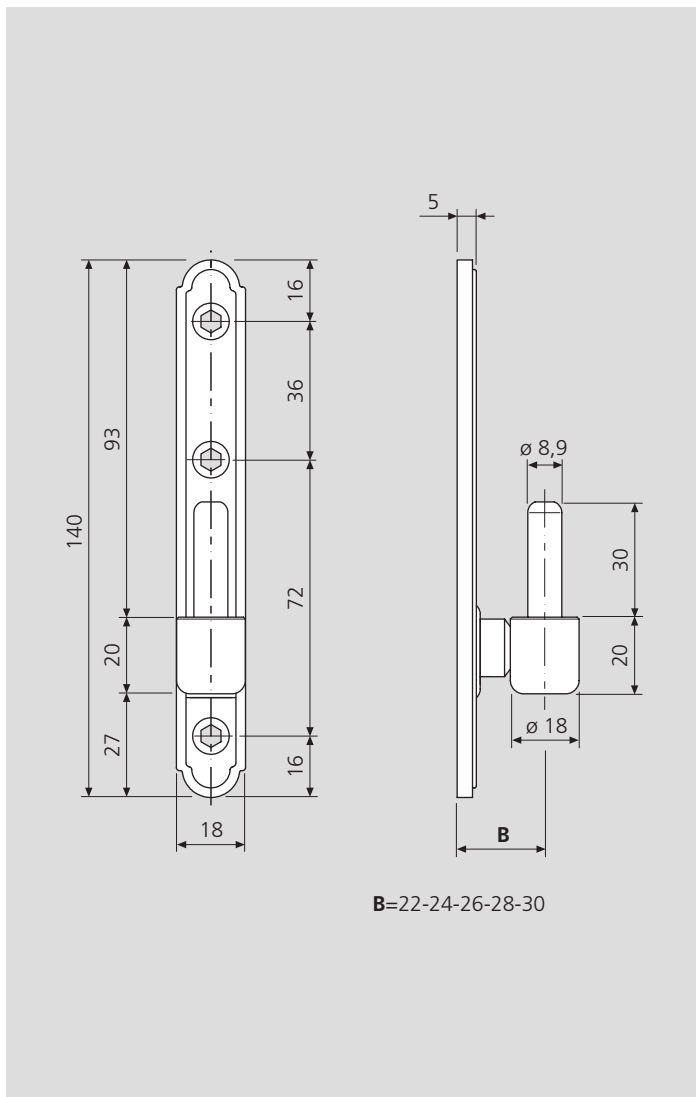

Order specifications

Order specifications		Black finish	Bichromated finish
GR	B	Code	Code
5	22	H01924.22.93	H01924.22.04
6	24	H01924.24.93	H01924.24.04
7	26	H01924.26.93	H01924.26.04
8	28	H01924.28.93	H01924.28.04
9	30	H01924.30.93	H01924.30.04