

# Adjustable hinge - with variable neck



**Description**

Reversible (two-handed) hinge with 2 stainless steel screws that enable horizontal and pressure adjustment using a 4 mm Allen wrench. Hinge reversibility is made possible thanks to a removable self-lubricating plastic bushing.

**Application**

Designed for simple monoblocs or systems with soffit and reveal to be cleared in order to open the shutter 180°. Used in combination with pintles featuring 9x30 mm pivot, and with supports with 26 mm screw hole. Use with pintles featuring 9 mm diameter pivot.

For GR size selection, see the "Application Range" tables.

**Mounting**

After mounting the hinge on the support, fasten using one of the following methods:

- 2 theft-proof screws
- two 4.5 mm screws of suitable length (matching the thickness of the shutter) and thread;
- rivets (only for PVCu or aluminium)

- We recommend the use of theft-proof screws as they ensure greater system steadiness and security.

- For direct attachment of the hinge to the shutter (without any brackets) use the compensating shim.

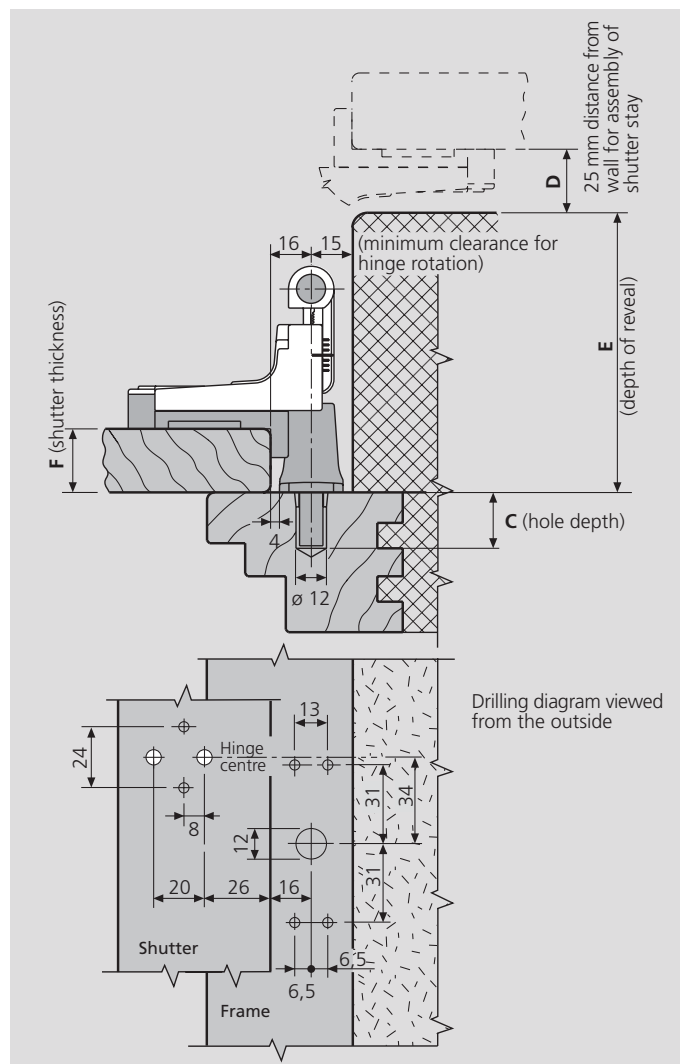
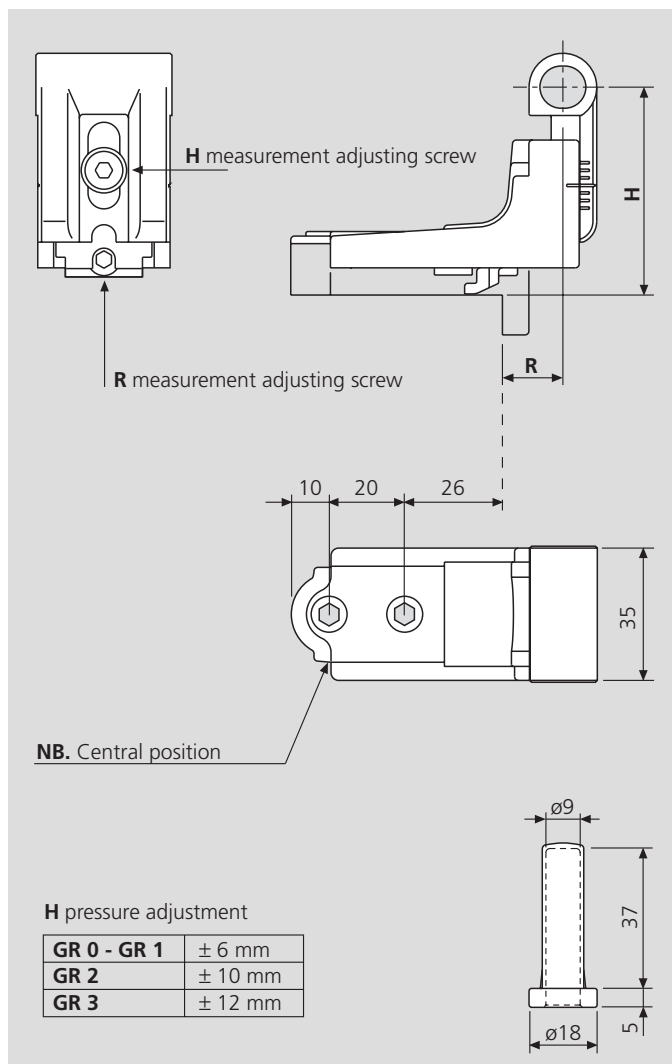

**Order specifications**

GR	H			R			Black finish	Bichromated finish
	min	centr.	max	min	centr.	max	Code	Code
0	36	42	48	12	16	20	H00914.00.93	H00914.00.04
1	49	55	61	12	16	20	H00914.01.93	H00914.01.04
2	62	72	82	12	16	20	H00914.02.93	H00914.02.04
3	82	94	106	12	16	20	H00914.03.93	H00914.03.04