

Adjustable pintle with narrow bracket



Description

Cold-pressed steel pintle, 9.2x12 mm shank with oval-vertical cross section. Two-handed bracket with stainless steel non-removable fastening dowel that uses a 4 mm Allen wrench.

Application

For shutters with useful space between bracket's outer edge and shutter greater than 29 mm.

Designed for simple monoblocs or systems with soffit and reveal to be cleared in order to open the shutter 180°.

For GR size selection, see the "Application Range" tables.

- Used in combination with adjustable hinges and relative supports to be chosen based on the shutter design.

- For special requirements it can also be used with all the other hinges.

Mounting

For the bracket, use four 4.5x35 mm screws with thread suitable for the shutter material.

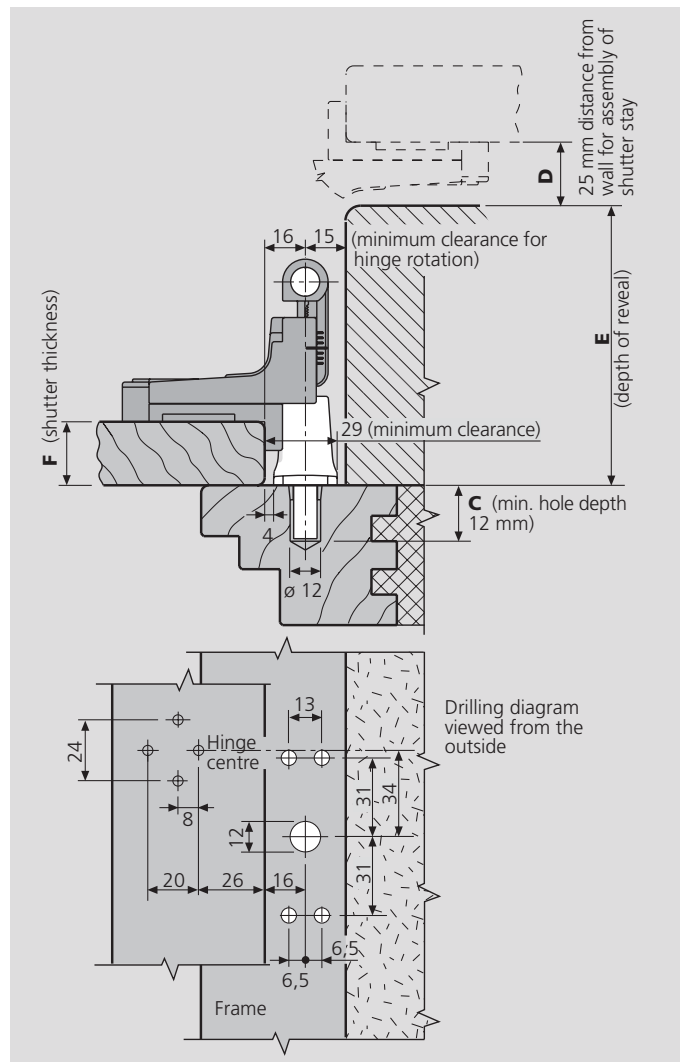
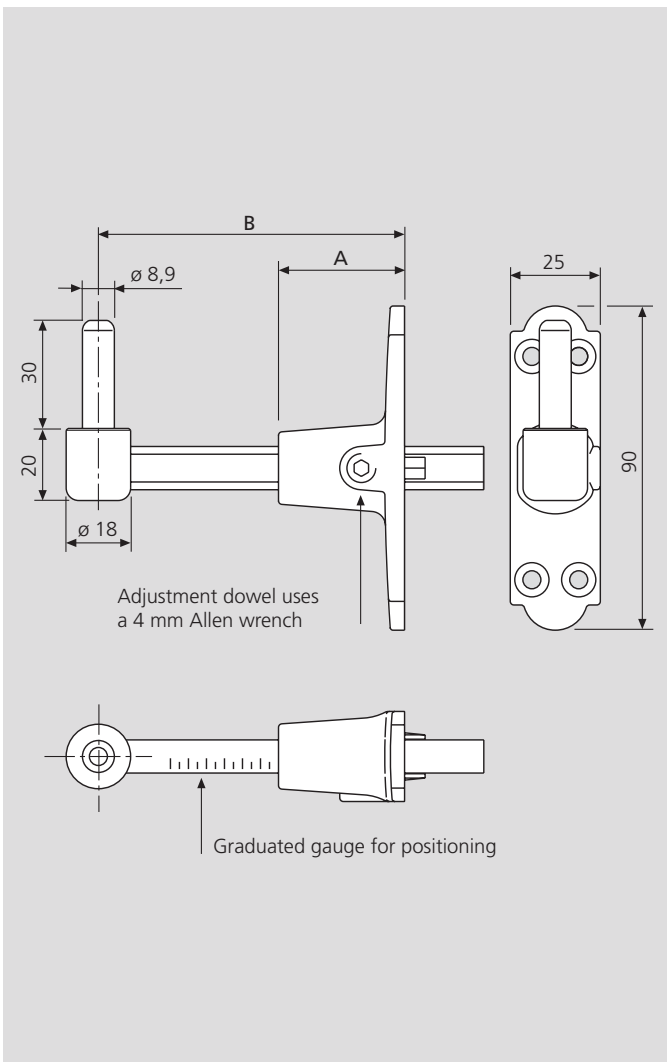

Order specifications

GR	Reveal E (*)	A	B	C	Black finish	Bichromated finish
					Code	Code
0	62-70	15,5	25÷55	67-B	H00911.00.93	H00911.00.04
1	67-125	35	55÷85	97-B	H00911.01.93	H00911.01.04
2	97-190	50	85÷115	127-B	H00911.02.93	H00911.02.04
3	145-225	65	115÷145	157-B	H00911.03.93	H00911.03.04

(*) The values refer to a distance D between the open shutter and the wall of 25 mm. For different distances see the "Application Range" chapter.